

# BLUFIRE™

## PEDOMETER



OWNER'S MANUAL

# TABLE OF CONTENTS

Congratulations on your purchase of the BLUFIRE™ Pedometer, the ultimate tool to set and meet your fitness goals. These instructions will help get you started.

|  |    |
|--|----|
| <b>Correct Pedometer Usage</b> . . . . . | 3  |
| <b>Basic Modes</b> . . . . .             | 4  |
| Time Mode. . . . .                       | 6  |
| Walk/Run Mode. . . . .                   | 7  |
| Memory Mode . . . . .                    | 9  |
| <b>Quick Start Guide</b> . . . . .       | 10 |
| User Data Mode. . . . .                  | 12 |
| Pacer Mode . . . . .                     | 14 |
| Alarm Mode. . . . .                      | 15 |
| Stopwatch Mode . . . . .                 | 15 |
| <b>FM Radio</b> . . . . .                | 16 |
| <b>Battery Replacement</b> . . . . .     | 17 |
| <b>Care and Maintenance</b> . . . . .    | 18 |

## CORRECT PEDOMETER USAGE

- Clip the pedometer onto your belt or waistband with the removable clip. Make sure the pedometer is perpendicular to the ground. The maximum tilt tolerance is  $-30^{\circ}/+30^{\circ}$ .
- Wear solid shoes.
- Jog or walk at a steady pace.
- Do not walk extremely slow or at an unsteady pace.
- Up-and-down movements or vibration (ex. car movement) can generate an incorrect reading.

## BASIC MODES

This pedometer has seven basic modes:

- Time (Default Screen)
- Walking Summary
- Memory Summary
- User Data (Age, Weight, Pace Walk, Pace Run, Goal)
- Pace
- Alarm
- Stopwatch

Press **MODE** to cycle through the modes. Press **ADJUST** to edit the data/settings in each mode.

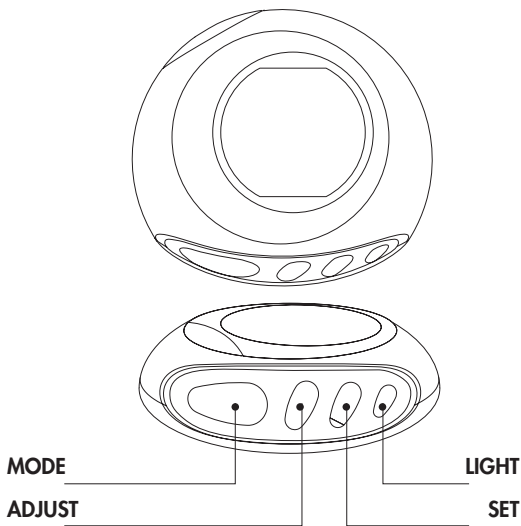

## DEFAULT SCREEN (TIME)

The default display for the pedometer shows the DATE/TIME. The third row will display STEP COUNT or press **SET** to cycle through these options:

STEP COUNT → CALORIES BURNED → DISTANCE → SPEED →  
% OF TARGET GOAL → EXERCISE TIMER

*NOTE: All the exercise information will be reset at 12:00AM each day. The previous day's exercise information is then stored in memory. You cannot reset the step count within the TIME mode.*

To set the time, press and hold **ADJUST** for two seconds. The HOUR digits will flash.

Press **SET** to increase (+) the digits.

Press **MODE** to switch to MINUTES.

Press **SET** to increase (+) the digits.

Press **MODE** to switch to SECONDS.

Press **SET** to reset the seconds to zero.

Press **MODE** to change DAY/MONTH/YEAR and the 12/24 HOUR display format. Press **SET** to adjust. **MODE** confirms.

## WALK/RUN MODE

Press and hold **SET** to cycle through WALK mode and RUN mode.

STEP COUNT + EXERCISE TIMER →

DISTANCE + STEP COUNT →

CALORIES BURNED + STEP COUNT →

SPEED + STEP COUNT

Toggle **SET** to select the display combination. Press and hold **ADJUST** to clear the current day's step counts. Previous days' memory will not be cleared.

## Measure Your Stride Distance

Accurate distance is measured from the tip of one foot to the other. To measure the correct average stride distance, divide the total distance of 10 steps by 10.

Stride distance is calculated in the following way:

TOTAL DISTANCE ÷ NUMBER OF STEPS = STRIDE DISTANCE

*Example: 20 feet ÷ 10 = 2 feet (24 inches)*

You'll need to measure the stride distance for both walking and running. To measure the stride distance for running, it is recommended to take more steps (approximately 50 steps) to get an accurate stride distance.

## Start Walking

While calculating step count, the display of the pedometer will begin showing the number of steps taken after the fifth step. The display will not change for five steps after you start walking. However, all steps taken will be counted and displayed.

## MEMORY MODE

The pedometer stores STEP COUNT, CALORIES BURNED, DISTANCE traveled, and the % OF GOAL achieved for seven consecutive days.

Press **SET** to review stored data. The display will show DATE and STEP COUNT. Press **SET** to review CALORIES BURNED, DISTANCE, and % OF GOAL.

*NOTE: For days when the pedometer is not used, the display will show the data as ZERO.*

To clear the seven-day memory press and hold **ADJUST** until the display shows NO INFO. New data will be stored the next day.

*NOTE: You cannot clear the exercise record of individual days.*

|  |                        |        |   |
|--|------------------------|--------|---|
|  | <b>Default Screen</b>  | ↓ MODE | Press and hold ↓ <b>ADJUST</b>  |
|  | <b>Walking Summary</b> | ↓ MODE | Press and hold ↓ <b>ADJUST</b><br>Press ↓ <b>SET</b> to cycle           |
|  | <b>Memory Summary</b>  | ↓ MODE |   |
|  | <b>User Data (Age)</b> | ↓ MODE | Press and hold ↓ <b>ADJUST</b><br>Press ↓ <b>SET</b> to cycle           |
|  | <b>Pace</b>            | ↓ MODE | Press ↓ <b>SET</b> to turn <b>OFF</b><br>Press and hold ↓ <b>ADJUST</b> |
|  | <b>Alarm</b>           | ↓ MODE | Press ↓ <b>SET</b> to turn <b>OFF</b><br>Press and hold ↓ <b>ADJUST</b> |
|  | <b>Stopwatch</b>       | ↓ MODE | Press ↓ <b>ADJUST</b> to <b>START</b>                                   |

**ADJUST** to adjust DATE/TIME

**ADJUST** to reset total WALK count  
through STEP COUNT, MILEAGE, CALORIES, MILES PER HOUR

**ADJUST** to reset AGE. Press ↓ **SET** to change YEAR. ↓ **MODE** confirms.  
through AGE, WEIGHT, PACE WALK, PACE RUN, GOAL

ON or OFF  
**ADJUST** to adjust PACE

ON or OFF  
**ADJUST** to adjust ALARM

START or STOP

## USER DATA MODE

The pedometer calculates data based on the following:

AGE → WEIGHT → WALKING STRIDE DISTANCE → RUNNING STRIDE DISTANCE → TARGET GOAL

To view user data, press **SET** to cycle through the above.

To set or change your data, press and hold **ADJUST** until AGE begins to flash.

### Set Age

To set your AGE, press **SET**. Press **MODE** to confirm.

*NOTE: The range for AGE is from 5 to 99.*

### Set Weight

To set your WEIGHT, press **SET**. Press **MODE** to confirm.

*NOTE: The range is from 44 to 331 lbs.*

## Set Stride Distance

To set your WALK STRIDE DISTANCE, press **SET**. Press **MODE** to confirm.

To set your RUN STRIDE DISTANCE, press **SET**. Press **MODE** to confirm.

## Set Target Step Goal

To set your GOAL, the first digit will start flashing. You can either press **SET** to adjust the digit and **MODE** to confirm or simply press **MODE** to move to the next digit. After you have set all the digits, press **MODE** to confirm.

*NOTE: The minimum value is 100 steps.*

## PACER MODE

The PACER function helps you walk or run to your set pace.

To set your pace, press and hold **ADJUST** until PACE begins to flash. Press **SET** to select the pace you want. The options (beats per minute) are:

30 → 50 → 60 → 70 → 80 → 90 → 100 →  
110 → 120 → 130 → 140 → 160 → 180

Press **ADJUST** to confirm.

To turn ON the pacer, press **SET**. The pacer will start beeping your pace in all modes.

To turn OFF the pacer, press **SET** from PACE mode.

## ALARM MODE

The pedometer also has a daily ALARM function. Press **SET** to toggle between ON and OFF.

To set the alarm, press and hold **ADJUST** to select a time. The alarm will automatically turn ON. Press the **SET** key to increase the HOUR digits. Press **MODE** to confirm. Press **SET** to increase the MINUTE digits. Press **MODE** to confirm.

## STOPWATCH MODE

Another feature of the pedometer is a STOPWATCH function. Press **ADJUST** to toggle between START and STOP. The stopwatch will run in other modes. To reset the stopwatch to ZERO, press **SET**.

## FM RADIO

To turn the radio on, plug the headphone plug into the headphone jack.

To find the lowest frequency station, press **RADIO RESET**. Press **SCAN** to cycle between stations.

Volume control is located on the earphone cable.

Unplug the earphone from the jack to turn the radio off.

## BATTERY REPLACEMENT

Use a screwdriver to unscrew the battery compartment cover on the back of the pedometer.

Use a thin stick to remove the battery from the pedometer. Insert a new 3V lithium battery type CR2032. Be sure to place the positive (+) side of the battery upward.

Replace the battery cover on the battery compartment and fasten the screw.

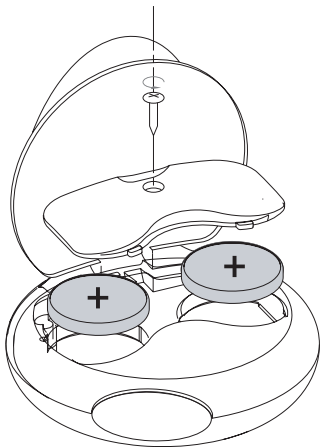

## CARE AND MAINTENANCE

- Never attempt to disassemble or service your pedometer.
- Protect the electronic module from extreme heat, shock and long time exposure to direct sunlight.
- Pedometer can be wiped clean with a lightly moistened cloth. Apply mild soap to the area if there are stubborn stains or marks. Do not expose the pedometer to strong chemicals such as gasoline, cleaning solvents, acetone, alcohol, or insect repellents as they may damage the pedometer's seal, case and finish.
- Store the pedometer in a dry place when you are not using it.
- Keep the pedometer out of reach of young children.
- If a young child swallows the battery, battery cover or screw, immediately consult a doctor.
- Keep the pedometer away from shock, magnetic fields, electrical noise and strong vibration.
- Do not swing the pedometer.
- Do not hang the pedometer from your neck during jogging.
- Do not drop or step on the pedometer.

- Do not put the pedometer in the back pocket of your shorts or pants
- Do not wash the pedometer or touch it with wet hands.

# BLUFIRE™

KHN Solutions LLC  
300 Broadway, Suite 26,  
San Francisco, CA 94133

Phone: 877-334-6876 Fax: 415-358-8030

Sales: [sales@blufire.com](mailto:sales@blufire.com)  
Service: [service@blufire.com](mailto:service@blufire.com)

[WWW.BLUFIRE.COM](http://WWW.BLUFIRE.COM)

© 2010 KHN Solutions LLC



A BluFire™ Product